

## HOLEMAKER PRO 75

### #3 MORSE TAPER, VARIABLE SPEED MACHINE



**Cutters**  
75mm



**Twist Drills**  
32mm



**Tapping**  
M24



**Spindle**  
MT3

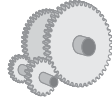

**Gearbox**  
80 - 160rpm  
210 - 420rpm

#### FEATURES

- No. 3 Morse taper spindle
- 2 speed gearbox with electronic variable speed, Electronic Speed Stabilization System (E.S.S.S.), and motor soft start
- Ideal for tapping up to M24
- Through spindle coolant system, with an external side mounted gravity feed coolant tank
- Left or right hand feed handle operation
- Unique semi-automatic gib adjustment system enables simple, fast and always correct fine tuning without any expert knowledge or experience
- Smart magnet technology to ensure sufficient magnetic adhesion
- Integrated cutter guard for increased user safety
- Supplied in a metal carry case

\*Supplied complete with arbor for use with Holemaker cutters up to 75mm depth of cut. Optional arbor to take Holemaker cutters up to 110mm depth of cut is available.

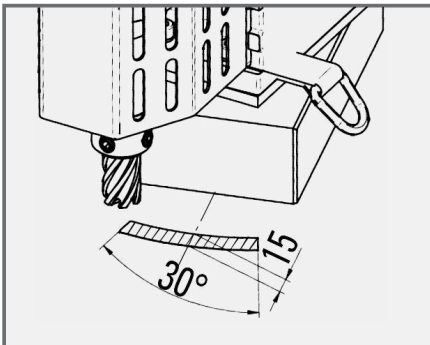

#### HOLEMAKER PRO 75 SR

- Additional jog reverse function and swivel base
- Once the drill has been fixed to the workpiece with the magnet, it can then be moved back and forward 15mm, or swivelled left and right 30°, and is then fastened into position with one socket head bolt

Part No.	<b>HMPRO75</b>
Part No.	<b>HMPRO75SR</b>
Capacity (Diameter)	75mm
Capacity (Depth)	110mm With Optional Arbor, 75mm Standard
Capacity (Twist Drills)	#3 Morse Taper 32mm
Motor Power	1650 Watt
Input Power	1800 Watt Single Phase 240V
Speed	2 Speed 80-160 / 210-420rpm
Weight	27kg
Magnetic Dead Lift	19,500Nm On 25mm Steel Plate
Stroke	214mm
Height (Min. / Max.)	525 / 739mm

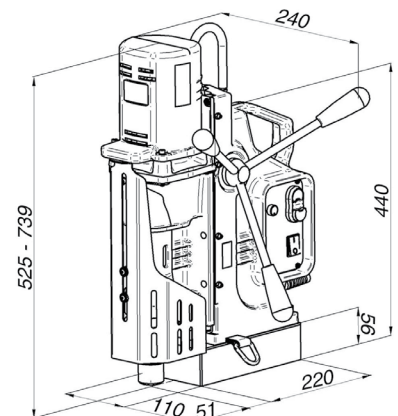

**EUROPEAN  
MADE QUALITY**

